

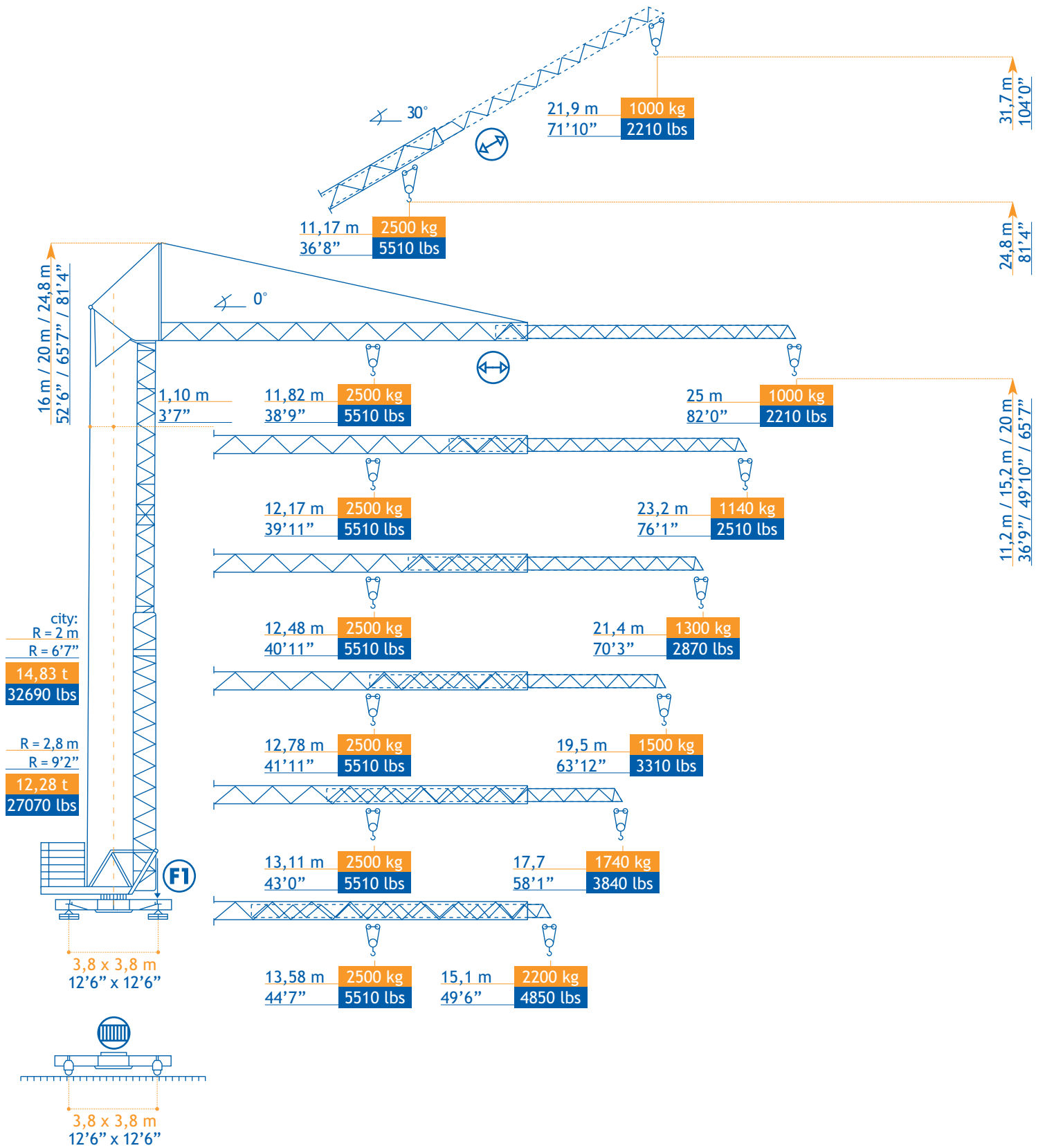

T 25A



Konform richtlijn 84/534 EEG gewijzigd door 87/405 EEG betreffende geluidsvermogensniveau van bouwkransen - Conforme à la directive 84/534 CEE modifiée par la directive 87/405 CEE concernant le niveau de puissance acoustique admissible des grues à tour - In compliance with guideline 84/534 EEG modified by 87/405 EEG regarding noise levels of building cranes - Im Sinne von Richtlinie 84/534 EWG, geändert durch Richtlinie 87/405 EWG zum Schalleistungspegel bei Baukränen - Conformemente alla direttiva 84/534 CEE, modificata dalla direttiva 87/405 CEE riguardante il livello sonoro delle gru - Conforme a la directx 84/534 CEE modificada por 87/405 CEE con respecto al nivel de capacidad acústica de grúas de construcción - DIN 15018 H1 - B3





LASTENTABEL - COURBES DE CHARGES - LOAD CURVES - LASTKURVEN - CURVE DI CARICO - CURVAS DE CARGAS

m	11,82	12	14	16	18	20	22	25
kg	2500	2450	2030	1725	1495	1315	1170	1000
ft	38'9"	39'4"	45'11"	52'6"	59'1"	65'7"	72'2"	82'0"
lbs	5510	5400	4480	3800	3300	2900	2580	2210

m	12,17	14	16	18	20	22	23,2
kg	2500	2106	1790	1552	1366	1216	1140
ft	39'11"	45'11"	52'6"	59'1"	65'7"	72'2"	76'1"
lbs	5510	4640	3950	3420	3010	2680	2510

m	12,48	14	16	18	20	21,4
kg	2500	2175	1848	1603	1411	1300
ft	40'11"	45'11"	52'6"	59'1"	65'7"	70'3"
lbs	5510	4800	4070	3530	3110	2870

m	12,48	14	16	18	19,5
kg	2500	2236	1940	1652	1500
ft	40'11"	45'11"	52'6"	59'1"	63'12"
lbs	5510	4930	4280	3640	3310

m	13,11	14	16	17,7
kg	2500	2308	1965	1740
ft	43'0"	45'11"	52'6"	58'1"
lbs	5510	5090	4330	3840

m	13,58	15,1
kg	2500	2200
ft	44'7"	49'6"
lbs	5510	4850

HOEKDRUKKEN - RÉACTIONS - REACTIONS - ECKDRÜCKE - REAZIONI - REACCIONES

F1

	kN	147
	kips	33

F1

	kN	116
	kips	26

	kg	10 400
	lbs	22 930

AANDRIJVINGEN - MÉCHANISMES - MECHANISMS - ANTRIEBE - MECCANISMI - MECANISMOS



max. 2500 kg

m/min	5,0	22,5	45,0
kg	2500	2500	1250
fpm	16	74	148
lbs	5510	5510	2760
kW	9,0	9,0	9,0
HP	~12,1	~12,1	~12,1

	m/min	20 / 40	2,2 kW
	fpm	~66 / 131	~2,9 HP

	tr/min	0 - 1	2,2 kW
			~2,9 HP

	m/min	25	2 x 1 kW
	fpm	~82	~2 x 1,3 HP

	kVA	19
--	-----	----

	V	220 - 380 V / 50 Hz
--	---	---------------------

MONTAGE - MONTAGE - ERECTION - MONTAGE - MONTAGGIO - MONTAJE

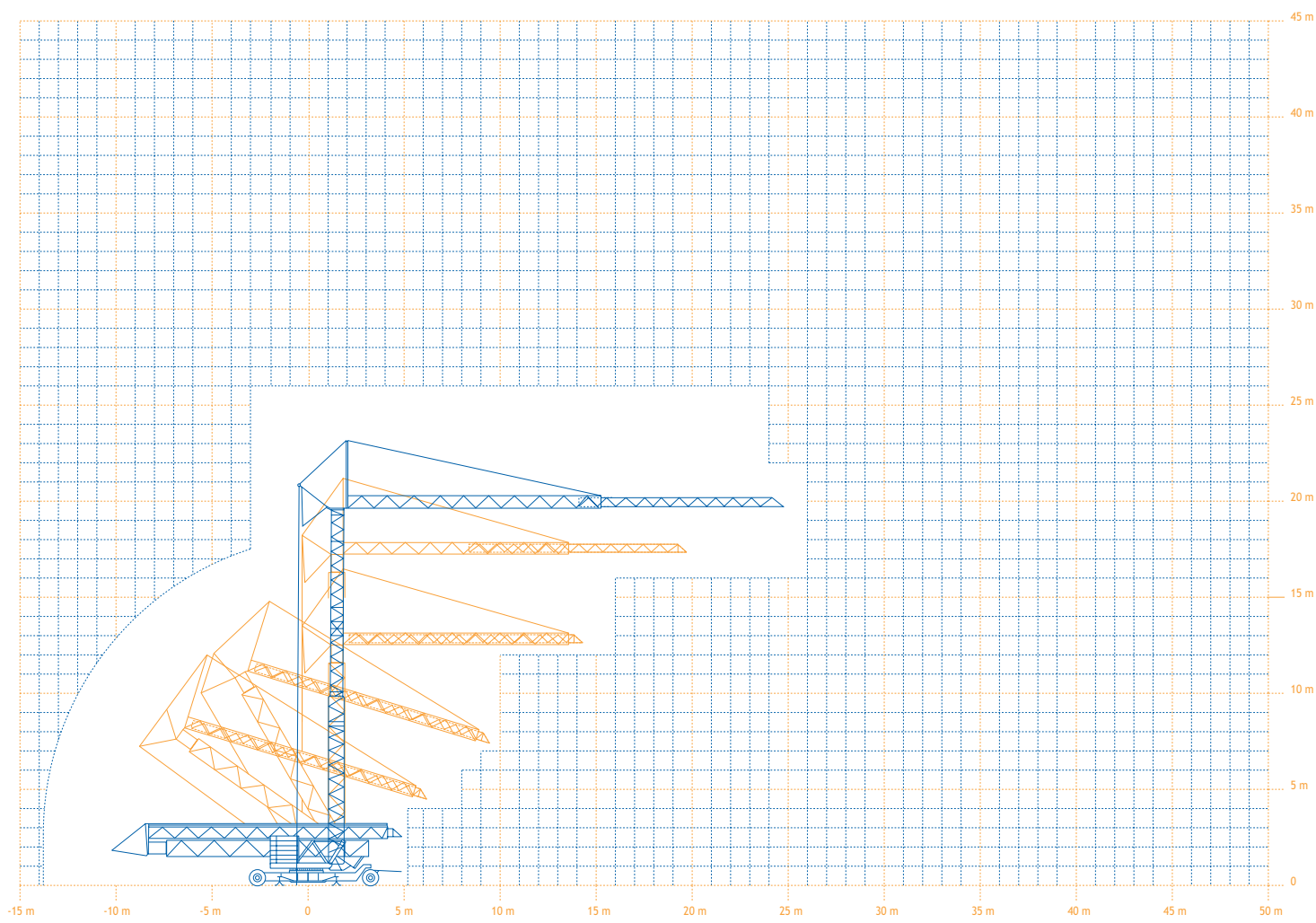

TRANSPORT

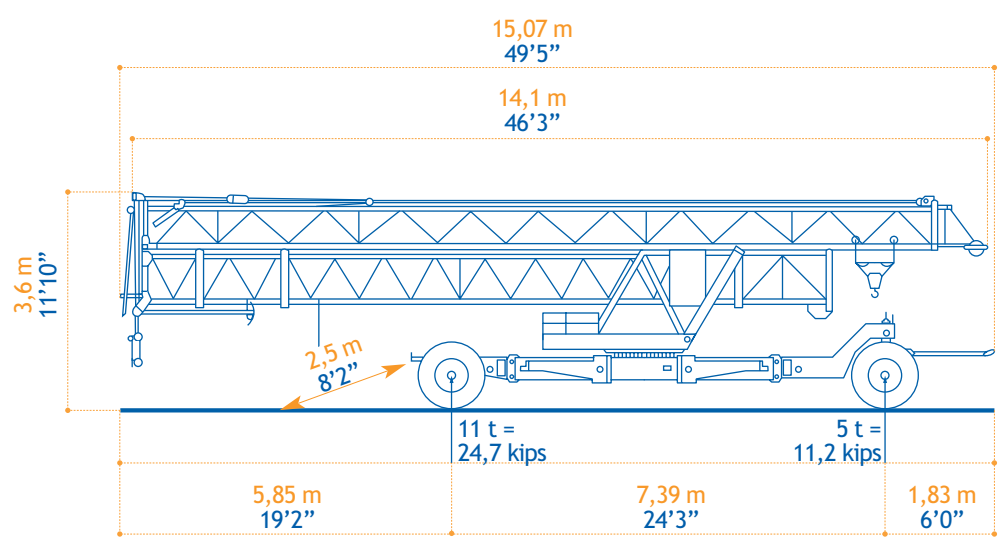



- in bedrijf
- en service
- in service
- in Betrieb
- in servizio
- en servicio



- lengte
- longueur
- length
- länge
- lunghezza
- longitud



- enkel inschering zonder hijsblok
- simple mouflage sans moufle
- 2 fall reeving without houstingblock
- 2 Fach Einscherung ohne Hakenflasche
- passaggio semplice senza paranca
- solamente elevación sin polea



- buiten bedrijf
- hors service
- out of service
- außer Betrieb
- fuori servizio
- fuera de servicio



- spoor
- translation
- rail
- Kranfahren
- carreggiata
- rail



- enkel inschering met hijsblok
- simple mouflage avec moufle
- 2 fall reeving with houstingblock
- 2 Fach Einscherung mit Hakenflasche
- passaggio semplice con paranca
- solamente elevación con polea



- hijsen
- levage
- hoisting
- heben
- sollevamento
- elevación



- vermogen
- puissance
- power
- leistung
- potenza
- potencia



- dubbel inschering
- double mouflage
- 4 fall reeving
- 4 Fach Einscherung
- passaggio doppio
- elevación doble



- loopkatrijden
- chariotage
- jib trolleying
- Katzfahren
- traslazione carrello
- poleas móviles



- micro snelheid
- vitesse
- speed
- Geschwindigkeit
- velocità
- velocidad



- zwenken
- orientation
- slewing
- Schwenken
- rotazione
- orientación



- 2° snelheid
- 2° vitesse
- 2° speed
- 2° Geschwindigkeit
- 2° velocità
- 2° velocidad



- spanning
- tension
- voltage
- spannung
- tensione
- tensión



- 3° snelheid
- 3° vitesse
- 3° speed
- 3° Geschwindigkeit
- 3° velocità
- 3° velocidad



- gewicht zonder ballast
- poids propre sans lest
- weight without ballast
- gewicht ohne Ballast
- peso senza zavorra
- peso sin lastre



- maximale hoekdruk
- réactions
- reactions
- Eckdrücke : 10 kN = 1t
- pressione angolare massima
- presión angular máxima

