

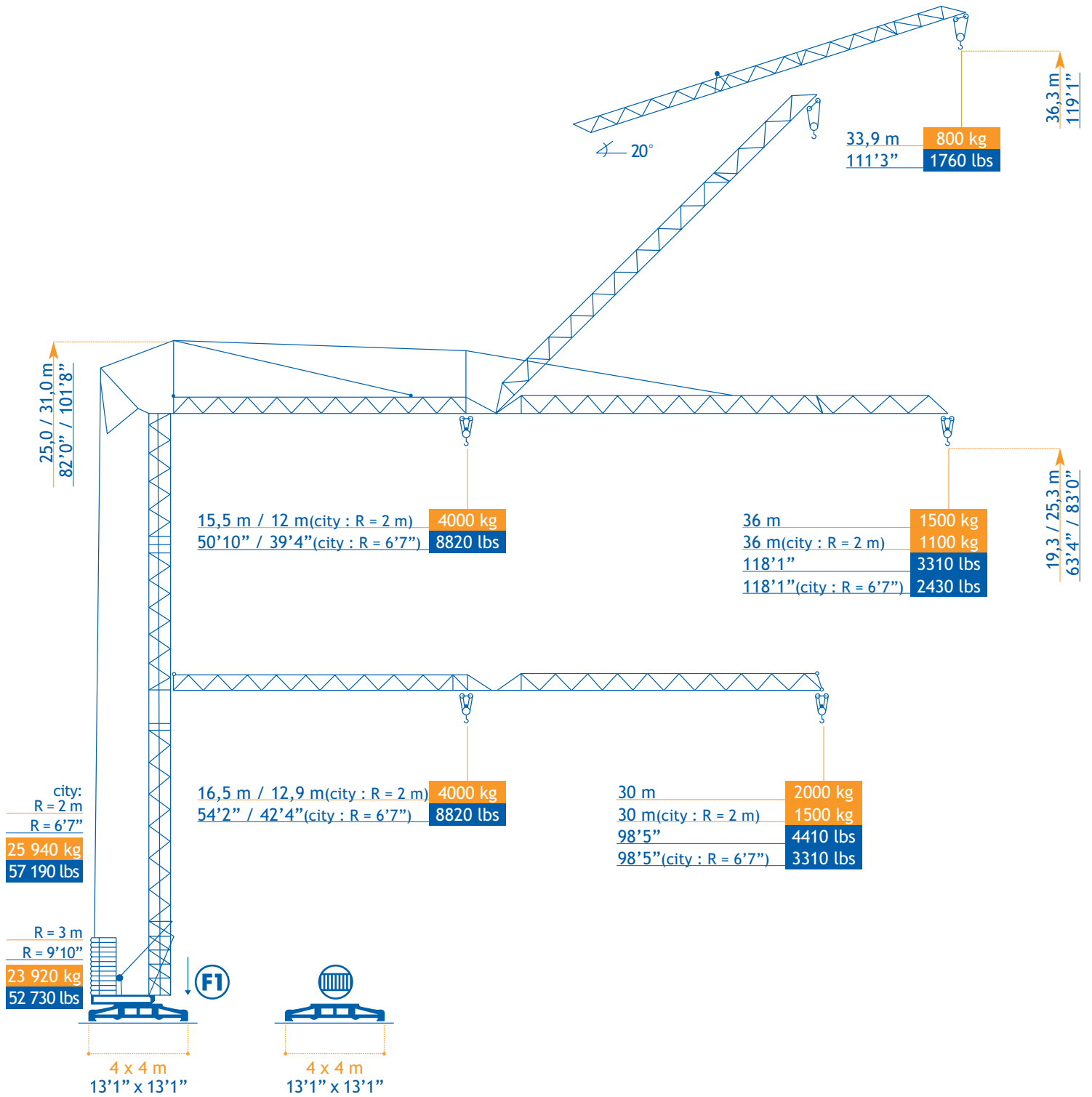

# A 36B



Konform richtlijn 84/534 EEG gewijzigd door 87/405 EEG betreffende geluidsvermogensniveau van bouwkransen - Conforme à la directive 84/534 CEE modifiée par la directive 87/405 CEE concernant le niveau de puissance acoustique admissible des grues à tour - In compliance with guideline 84/534 EEG modified by 87/405 EEG regarding noise levels of building cranes - Im Sinne von Richtlinie 84/534 EWG, geändert durch Richtlinie 87/405 EWG zum Schalleistungspegel bei Baukränen - Conformemente alla direttiva 84/534 CEE, modificata dalla direttiva 87/405 CEE riguardante il livello sonoro delle gru - Conforme a la directiv 84/534 CEE modificada por 87/405 CEE con respecto al nivel de capacidad acústica de grúas de construcción - DIN 15018 H1 - B3





VEREISTE MONTAGERUIMTE - ENCOMBREMENT AU MONTAGE - SPACE REQUIREMENT - ABMESSUNGEN - SPAZIO NECESSARIO PER IL MONTAGGIO

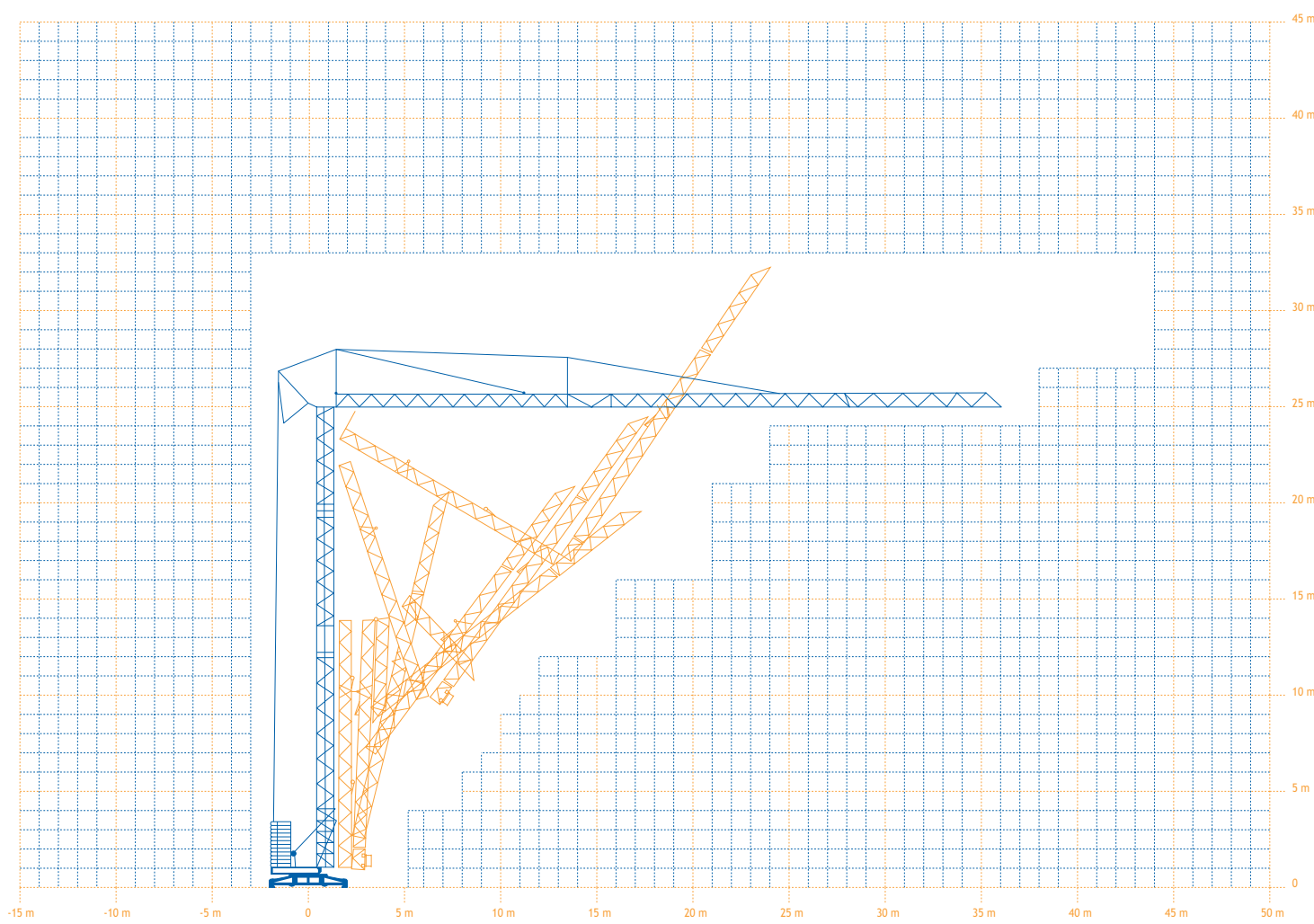

TRANSPORT

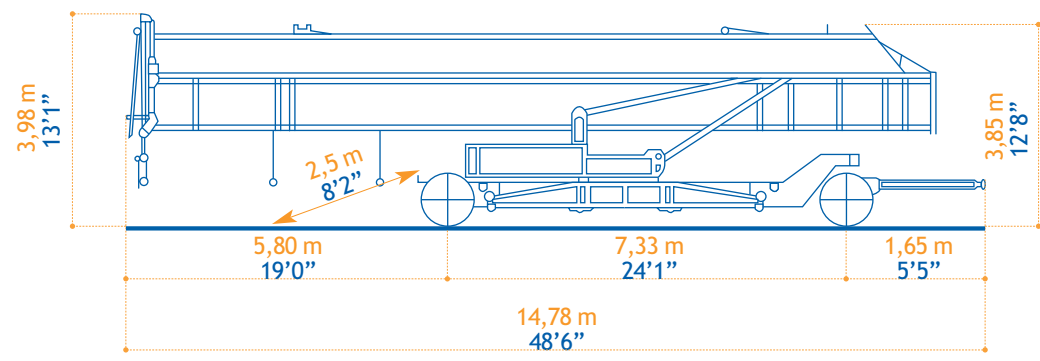



- in bedrijf
- en service
- in service
- in Betrieb
- in servizio
- en servicio



- lengte
- longueur
- length
- länge
- lunghezza
- longitud



- enkel inschering zonder hijsblok
- simple mouflage sans moufle
- 2 fall reeving without houstingblock
- 2 Fach Einscherung ohne Hakenflasche
- passaggio semplice senza paranca
- solamente elevación sin polea



- buiten bedrijf
- hors service
- out of service
- außer Betrieb
- fuori servizio
- fuera de servicio



- spoor
- translation
- rail
- Kranfahren
- carreggiata
- rail



- enkel inschering met hijsblok
- simple mouflage avec moufle
- 2 fall reeving with houstingblock
- 2 Fach Einscherung mit Hakenflasche
- passaggio semplice con paranca
- solamente elevación con polea



- hijsen
- levage
- hoisting
- heben
- sollevamento
- elevación



- vermogen
- puissance
- power
- leistung
- potenza
- potencia



- dubbel inschering
- double mouflage
- 4 fall reeving
- 4 Fach Einscherung
- passaggio doppio
- elevación doble



- loopkatrijden
- chariotage
- jib trolleying
- Katzfahren
- traslazione carrello
- poleas móviles



- micro snelheid
- vitesse
- speed
- Geschwindigkeit
- velocità
- velocidad



- zwenken
- orientation
- slewing
- Schwenken
- rotazione
- orientación



- 2° snelheid
- 2° vitesse
- 2° speed
- 2° Geschwindigkeit
- 2° velocità
- 2° velocidad



- spanning
- tension
- voltage
- spannung
- tensione
- tensión



- 3° snelheid
- 3° vitesse
- 3° speed
- 3° Geschwindigkeit
- 3° velocità
- 3° velocidad



- gewicht zonder ballast
- poids propre sans lest
- weight without ballast
- gewicht ohne Ballast
- peso senza zavorra
- peso sin lastre



- maximale hoekdruk
- réactions
- reactions
- Eckdrücke : 10 kN = 1t
- pressione angolare massima
- presión angular máxima

