

Voor "VERSION CITY", contacteer ons. Pour "VERSION CITY", consultez nous. For "VERSION CITY", contact us. Für "VERSION CITY", kontaktieren Sie uns.



LASTENTABEL - COURBES DE CHARGES - LOAD CURVES - LASTKURVEN - CURVE DI CARICO - CURVAS DE CARGAS

m	13,52	14	15	16	17	18	19	20	21	22	23	24	25	26	27	28	29	30
kg	4000	3833	3521	3252	3020	2816	2636	2476	2332	2203	2086	1980	1882	1793	1711	1635	1565	1500
ft	44'4"	45'11"	49'3"	52'6"	55'9"	59'1"	62'4"	65'7"	68'11"	72'2"	75'6"	78'9"	82'0"	85'4"	88'7"	91'10"	95'2"	98'5"
lbs	8820	8450	7760	7170	6660	6210	5810	5460	5140	4860	4600	4370	4150	3950	3770	3610	3450	3310

m	14,05	15	16	17	18	19	20	21	22	23	24	25	27,5	
kg	4000	3691	3411	3168	2955	2767	2599	2449	2314	2192	2081	1979	1886	1760
ft	46'1"	49'3"	52'6"	55'9"	59'1"	62'4"	65'7"	68'11"	72'2"	75'6"	78'9"	82'0"	85'4"	90'3"
lbs	8820	8140	7520	6980	6520	6100	5730	5400	5100	4830	4590	4360	4160	3880

m	14,75	15	16	17	18	19	20	21	22	23	24	25
kg	4000	3904	3608	3352	3128	2930	2753	2595	2453	2324	2207	2100
ft	48'5"	49'3"	52'6"	55'9"	59'1"	62'4"	65'7"	68'11"	72'2"	75'6"	78'9"	82'0"
lbs	8820	8610	7950	7390	6900	6460	6070	5720	5410	5120	4870	4630

m	15,25	16	17	18	19	20	21	22,5
kg	4000	3773	3506	3272	3066	2882	2717	2500
ft	50'0"	52'6"	55'9"	59'1"	62'4"	65'7"	68'11"	73'10"
lbs	8820	8320	7730	7210	6760	6350	5990	5510

m	15,75	16	17	18	19	20
kg	4000	3925	3648	3405	3191	3000
ft	51'8"	52'6"	55'9"	59'1"	62'4"	65'7"
lbs	8820	8650	8040	7510	7040	6610

m	16,29	17,5
kg	4000	3670
ft	53'5"	57'5"
lbs	8820	8090



m	24,81	25	26	27	28	29	30
kg	2000	1982	1893	1811	1735	1665	1600
ft	81'5"	82'0"	85'4"	88'7"	91'10"	95'2"	98'5"
lbs	4410	4370	4170	3990	3830	3670	3530

HOEKDRUKKEN - RÉACTIONS - REACTIONS - ECKDRÜCKE - REAZIONI - REACCIONES

F1

kN	235
kips	53

F1

kN	175
kips	39

kg	13 800
lbs	30 420

AANDRIJVINGEN - MÉCHANISMES - MECHANISMS - ANTRIEBE - MECCANISMI - MECANISMOS



max. 2000 kg

m/min	5,0	22,5	45,0	
kg	2000	2000	1200	
fpm	16	74	148	
lbs	4410	4410	2650	
kW	2,4	11,0	11,0	
HP	-3,2	-14,7	-14,7	



max. 4000 kg

m/min	2,5	11,3	22,5	
kg	4000	4000	2400	
fpm	8	37	74	
lbs	8820	8820	5290	
kW	2,4	11,0	11,0	
HP	-3,2	-14,7	-14,7	

m/min	25 / 50	1,5 kW	25 / 50	1,5 kW
fpm	-82 / 164	-2 HP	-82 / 164	-2 HP
tr/min	0 - 1	2,6 kW	0 - 1	2,6 kW
		-3,5 HP		-3,5 HP

kVA	25
-----	----

220 - 380 V / 50 Hz

VEREISTE MONTAGERUIMTE - ENCOMBREMENT AU MONTAGE - SPACE REQUIREMENT - ABMESSUNGEN - SPAZIO NECESSARIO PER IL MONTAGGIO

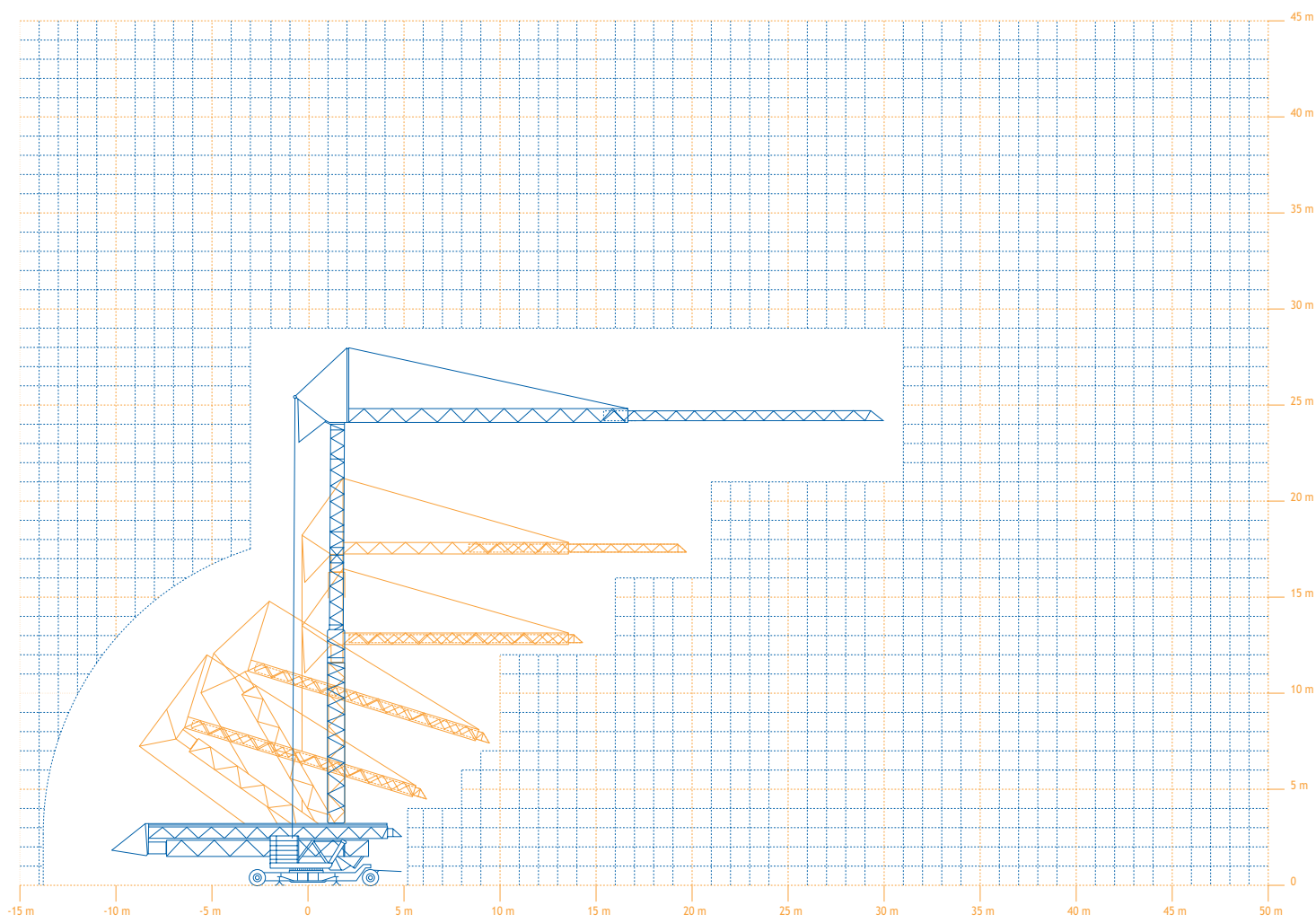

TRANSPORT

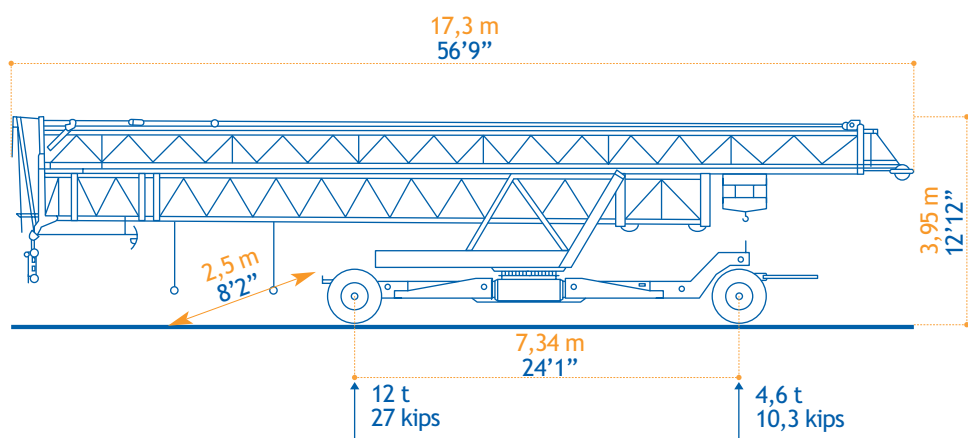



- in bedrijf
- en service
- in service
- in Betrieb
- in servizio
- en servicio



- lengte
- longueur
- length
- länge
- lunghezza
- longitud



- enkel inschering zonder hijsblok
- simple mouflage sans moufle
- 2 fall reeving without houstingblock
- 2 Fach Einscherung ohne Hakenflasche
- passaggio semplice senza paranca
- solamente elevación sin polea



- buiten bedrijf
- hors service
- out of service
- außer Betrieb
- fuori servizio
- fuera de servicio



- spoor
- translation
- rail
- Kranfahren
- carreggiata
- rail



- enkel inschering met hijsblok
- simple mouflage avec moufle
- 2 fall reeving with houstingblock
- 2 Fach Einscherung mit Hakenflasche
- passaggio semplice con paranca
- solamente elevación con polea



- hijsen
- levage
- hoisting
- heben
- sollevamento
- elevación



- vermogen
- puissance
- power
- leistung
- potenza
- potencia



- dubbel inschering
- double mouflage
- 4 fall reeving
- 4 Fach Einscherung
- passaggio doppio
- elevación doble



- loopkatrijden
- chariotage
- jib trolleying
- Katzfahren
- traslazione carrello
- poleas móviles



- micro snelheid
- vitesse
- speed
- Geschwindigkeit
- velocità
- velocidad



- zwenken
- orientation
- slewing
- Schwenken
- rotazione
- orientación



- 2° snelheid
- 2° vitesse
- 2° speed
- 2° Geschwindigkeit
- 2° velocità
- 2° velocidad



- spanning
- tension
- voltage
- spannung
- tensione
- tensión



- 3° snelheid
- 3° vitesse
- 3° speed
- 3° Geschwindigkeit
- 3° velocità
- 3° velocidad



- gewicht zonder ballast
- poids propre sans lest
- weight without ballast
- gewicht ohne Ballast
- peso senza zavorra
- peso sin lastre



- maximale hoekdruk
- réactions
- reactions
- Eckdrücke : 10 kN = 1t
- pressione angolare massima
- presión angular máxima

